

ESW-2140C TWO POST LIFT

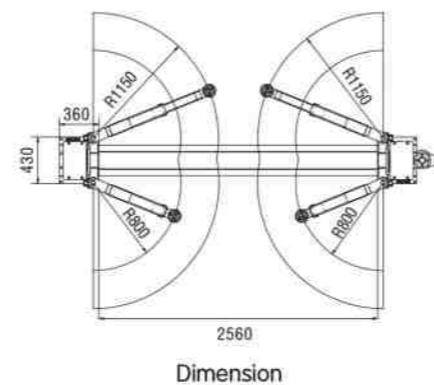
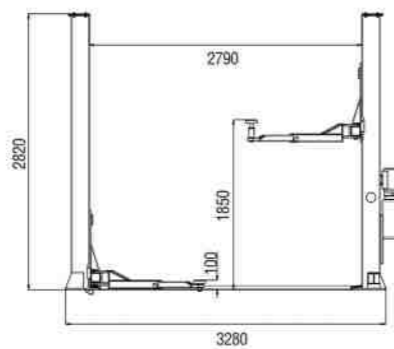
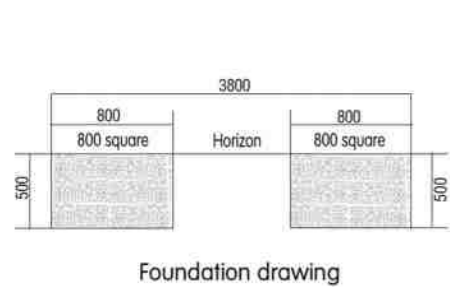

Features:

1. Floor design, suitable for the bottom not high in the auto repair.
2. Adopt double cylinder, 4*3 higher and stronger chain, the wire rope balance system.
3. Bilateral manual release.
4. Rubber pad door-opening protection.
5. Rubber support pad adopts double helix adjustment height and height increase joint.
6. Limit switch.
7. The arm adopts two stages or three stages design, larger range adjustment, suitable for different vehicle chassis, three-node arm optional installation.

Technical specifications:

Lifting capacity:	3500kg
Lifting height:	1850mm
Min.height:	100mm
Pass width:	2560mm
Column width:	2790mm
Total width:	3280mm
Lifting time:	50s-60s
Motor power:	2.2kw-380v/2.2kw-220v
Oil pressure rating:	24Mpa
Weight:	565kg

